



Viper™ Frozen Sparkling Beverage Dispenser

Specification Guide



VIPER™



Features

High Capacity

Surge capacity dispensing 10 (16oz) consecutive drinks per barrel with a continuous draw capacity of 75-82 fl.oz per minute

Patented Intelligent Defrost™

Manages product quality and bypasses unnecessary defrost times

Defrost Lock-Out Times

Schedule defrost lockout times to avoid down time during peak demand periods

Sleep Mode

Schedule sleep modes to conserve energy during off hours

Remote Condenser

Remote and air-cooled condenser options available

QR Code

Quickly access service manuals and easy-to-follow training videos

C3 Technology

Cooling, carbonation, and controls provide unmatched drink profile consistency and minimizes syrup usage

Serviceability

Reduced maintenance and service times with a 0.3% out of the box failure rate

Programmable Flavor Barrels

Individual barrel flexibility and profile settings

ADA Compliant

Stainless push handle valve



MARMON
Foodservice
Technologies

A BERKSHIRE HATHAWAY COMPANY



Viper™ Frozen Sparkling Beverage Dispenser

Specification Guide

Technical Specifications

Electrical Requirements	230V +/-15V 60Hz, 30A, single phase Includes 8ft. power NEMA L6-30P molded plug connection.
Pressure Requirements	CO2 = 75 psig Water = 25 min psig dynamic
Draw Capacity	75-82 oz/min continuous, alternating barrels @ 75° F (24°C)
Refrigeration	19,000 BTU, R448A
Minimum Clearance Requirements	Top: 12" (305mm) Both Sides: 2" (51mm) -or- Back: 2" (51mm) for temperatures < 90°F (32°C)
Unit Dimensions	22.75"W x 32.5"D x 37"H (577.85mm x 825.5mm x 939.8mm)
Graphic Card Dimensions	22.5"W x 11.79"H (571.5mm x 299.5mm)
Flavor Card Dimensions	6.5"W x 4"H (165.1mm x 101.6mm)
Unit Weight	Unit: 445lbs (199.6kg) Cart: 131lbs (60kg)
Shipping Weight	Unit: 465lbs (210.92kg) Cart: 185lbs (85kg)
Agency Listing	60 Hz

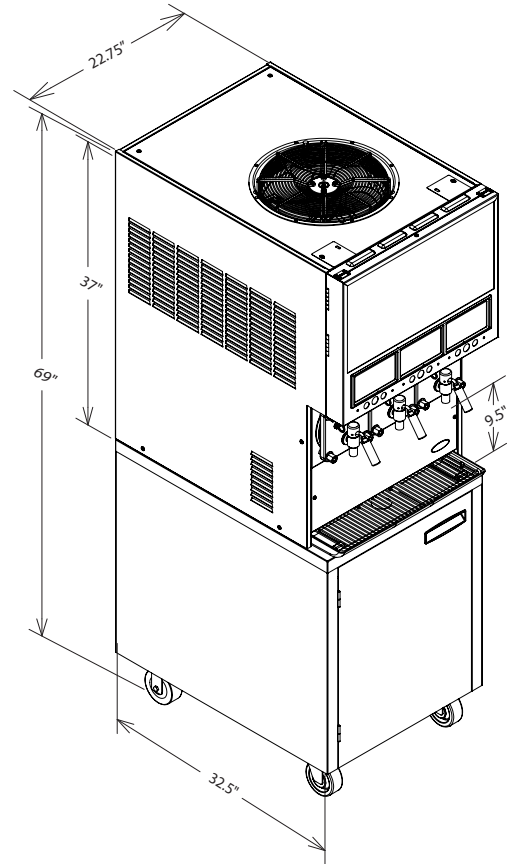

Model Number	Description
621366141MD22	Viper 3 Barrel, 60Hz, R448A, Air Cooled, Stainless Push Handle Valve (SPH), Short Merchandiser, N. American Power Cord

Note: When ordering the Remote Condensing Dispenser, the corresponding accessory below (marked with¹) must also be ordered. Additionally, one of the 2 line set options (marked with²) must also be ordered.

Accessories Number	Description
629087406	Leg kit, 4" legs adjustable to 5.25 inches
621058482	Viper™ 3 flavor cart, pre-plumbed, stainless steel
621058789	Viper™ 3 flavor cart, pre-plumbed, stainless steel, NSF
629097986	Viper™ 3 flavor cart plumbing kit ²
620067479	Pre-wired buck boost transformer
620067108	Viper™ 3 barrel remote condenser ¹
629097653	Installation kit, 100' without cart ^{**}
629097662	Installation kit, 100' with cart ^{**}
1BIFJ	BIB Rack 1 wide, stackable

Refer to Installation Manual for required installation materials
*Note: When ordering the Remote Condensing Dispenser, the corresponding accessory above (marked with¹) must also be ordered. Additionally, one of the 2 line set options (marked with^{**}) must also be ordered.*
Note: When ordering the Viper™ 3 flavor pre-plumbed cart (PN: 621058789), the corresponding model number above (marked with²) must also be ordered.

To learn more and see **Viper™** in action, visit cornelius.com
 To contact a Cornelius® expert today, visit cornelius.com/contact-us