

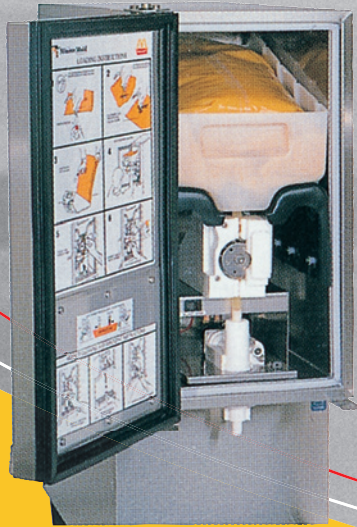

QLT 180

QUICK LOAD POUCH
ORANGE JUICE DISPENSER



FEATURES:

- One Product Selection
- Front Loading of Concentrate
- 6 liter (1.6 US gal.) disposable concentrate pouch capacity
- Portion Control Dispensing
- Accurate, Reloadable, 180° Peristaltic Pump
- Narrow profile – 10 3/4 in (272.8 mm) wide
- UL, CUL, CE and NSF Listed
- Adjustable Brix Control
- Simple Sanitation and Service
- Environmentally Friendly – R-134a Refrigerant
- Sturdy Stainless Steel Cabinet



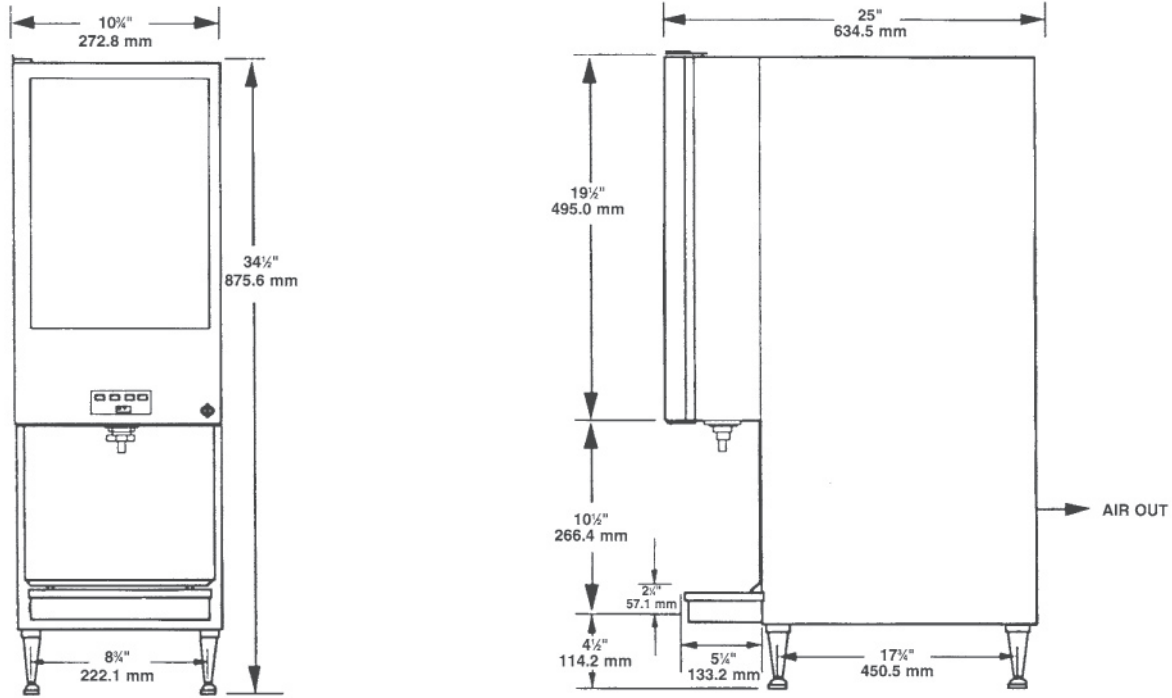

CATM8313-0306

JUICE



PART NUMBER	DESCRIPTION
45100401	QLT180 / 1000-1 Juice Dispenser for BIB, 115V
45100402	QLT180 / 1002-1 Juice Dispenser for BIB, 230V
45575	Conversion Kit for SLJ-1000 to QLT180 / 1000-1, Domestic
45575001	Conversion kit for SLJ-1002 to QLT180 / 1002-1, International

TECHNICAL SPECIFICATIONS:

ELECTRICAL RATING	1000-1 – 115V / 60 Hz / 9.4 Amps 002-1 – 230V / 50 Hz / 5 Amps	CONCENTRATE STORAGE	6 liter (1.6 US gal.) Disposable Pouch
REFRIGERATION	1/3 H.P. Hermetically Sealed System, R-134a Refrigerant 6.25 oz (177 g)	WATER SUPPLY REQUIREMENTS	100 psi (7 kg / sq cm) max static pressure 20 psi (1.4 kg / sq cm) min dynamic pressure
DIMENSIONS:		COOLING CAPACITY	Continuous 5 oz (147.85 ml) drinks at 4 per minute with 75°F (24°C) ambient and 45°F (5°C) concentrate without exceeding 45°F (7°C) temperature
HEIGHT	(with 4 in legs) 34 1/2 in (875.6 mm)	FLOW RATE	Adjustable water flow rate from 1.6 oz / sec (47.3 ml / sec) to 2.2 oz / sec (65 ml / sec)
WIDTH	10 3/4 in (272.8 mm)	AGENCY LISTINGS	 
DEPTH	25 in (634.5 mm)		
WEIGHTS:			
DRY WEIGHT	110 lb (50 kg)		
SHIPPING WEIGHT	143 lb (65 kg)		
WATER CONNECTION	3/8 in (9.5 mm) SAE male flare fitting on dispenser		

