



PHOENIX

DIGITAL BEVERAGE TOWER

Fun and easy new interface for brand selection

Modern look and maximum consumer engagement

Utilizes Standard BIB syrup

Up to 8 brands
Up to 4 Flavors



Touch Screen User Interface

Multi-Flavor Valves

Lighting for Targeting
Drink into Cup

ADA Compliant

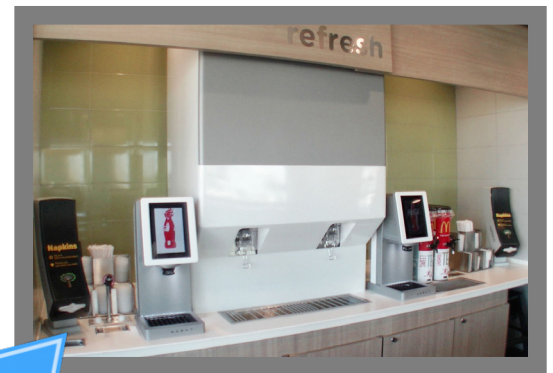

FEATURES

Tap and press interface to select and pour your choices

Interactive Dispense - Up to 8 brands and 4 flavor shots

Single Dispense Point - Provides simultaneous brand and flavor dispense

Flavor Shot - Blends with drink or top off for extra flavor

Easy to Clean - Materials, merchandising and lower panel

Functional - Utilize existing back room system and syrups

Merchandising - Video display delivers unique messaging

Ease of Use - Modular design allows for easy component access from the front of the unit

ADA Compliant - Meets ADA requirements on a 34" counter



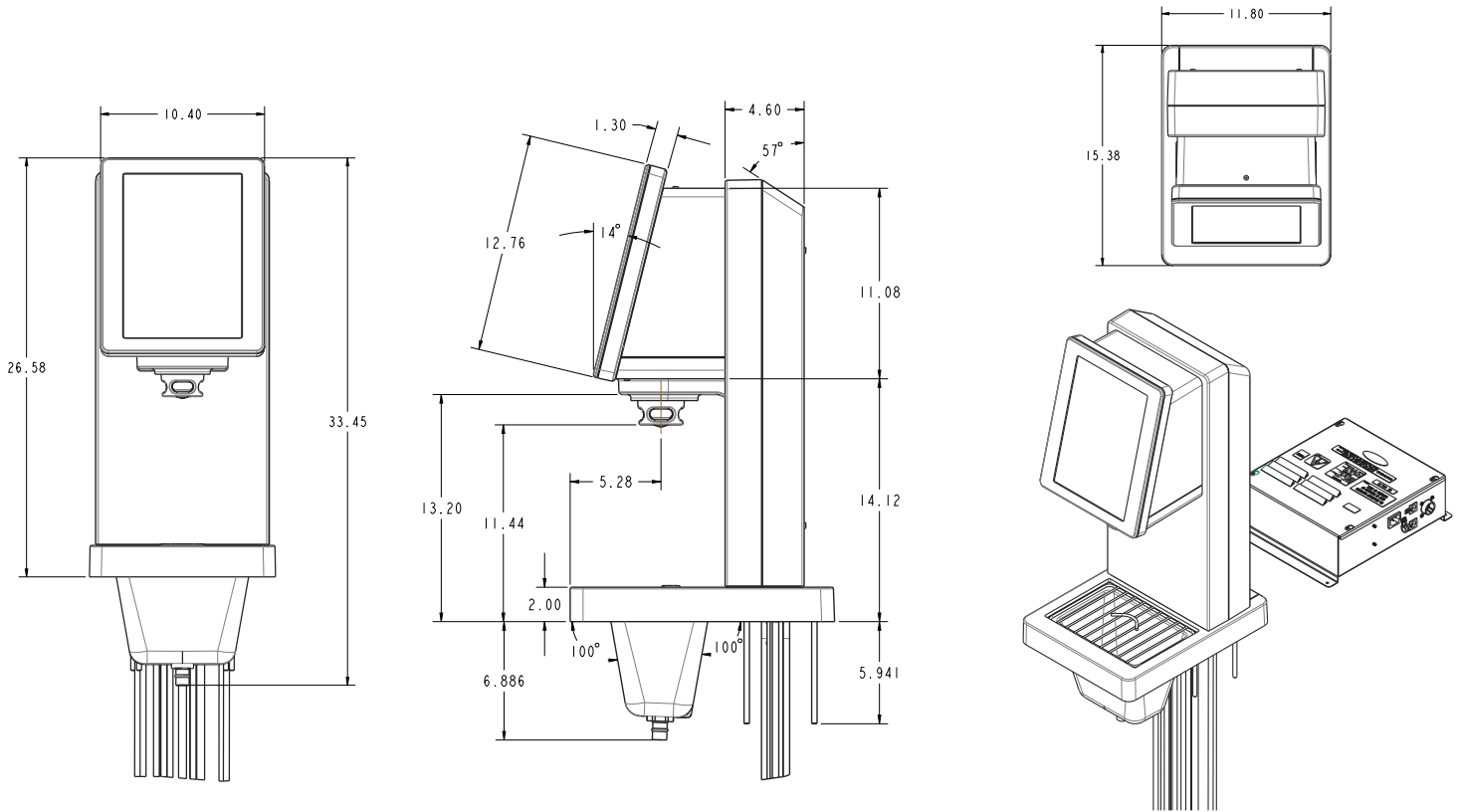

PART NUMBER	DESCRIPTION
621058641	Phoenix Digital Beverage Tower

TECHNICAL SPECIFICATIONS

DIMENSIONS 26.58"Hx11.80"Wx 15.38"D
SCREEN DIMENSIONS 8.5"Hx5"Wx10.1"Diagonally
VIDEO FORMAT MP4 (H.264) (800x1280)
VIDEO MAX SIZE 2GB
BRAND IMAGE 1 FORMATpng (230x230 pixels) and (170x170)
BRAND IMAGE 2 FORMAT png (300x300 pixels)
FLAVOR SHOT IMAGE FORMAT . . .png (250x250 pixels)
COUNTER WEIGHT 30 lb
SHIPPING WEIGHT 60 lb
AMP DRAW 115 V / 60 Hz / 1.5 Amps

ELECTRICAL RATING 115 V +/- 10% (only requires single outlet)
CO₂ 30 max psi at regulator for flavor shots
WATER SUPPLY PRESSURE 50-60 psi
8 AMBIENT BRAND SYRUPS 60 psi/min
4 FLAVOR SHOT SYRUPS 30 psi/max
VALVE Touch Screen
FLOW RATE FOR BRANDS 3oz./sec valves
CUP CLEARANCE 9.75"
AGENCY LISTINGS City of Los Angeles

Coca-Cola has approved the use of Trademarks but use of the Trademarks does not imply that Coca-Cola has approved or endorses the equipment.



© 2016 CORNELIUS CATM8735-0916

IN THE U.S.A.
 Ph: 800.238.3600
 Fax: 800.258.0255

OUTSIDE THE U.S.A.
 Ph: 763.488.8200
 Email: webmaster@cornelius.com

101 Broadway Street West
 Osseo, MN 55369
 www.cornelius-usa.com

For more information or to place an order, contact your sales representative or authorized distributor.