



Beverage Systems

CARD NO.
2

2

Planned Maintenance System Maintenance Requirement Card (MRC)

Equipment: Everpure Water Filtration System: Quad and Tri-Pack Systems

Precaution: Essential that this procedure be performed during non-business hours.

PICTURES AND ADDITIONAL INFORMATION: Corresponding Chapter of Equipment Manual

**Every 9
Months**

Cartridge Changeout

Tools:

- None required.

1. Shut OFF water to system. Turn OFF power to coffee, ice and post mix.
2. Connect garden hose to activation valve, run to drain and secure. Open activation valve on header by turning COUNTERCLOCKWISE to relieve water pressure. (Activation valve should remain open.) (Figure 1)

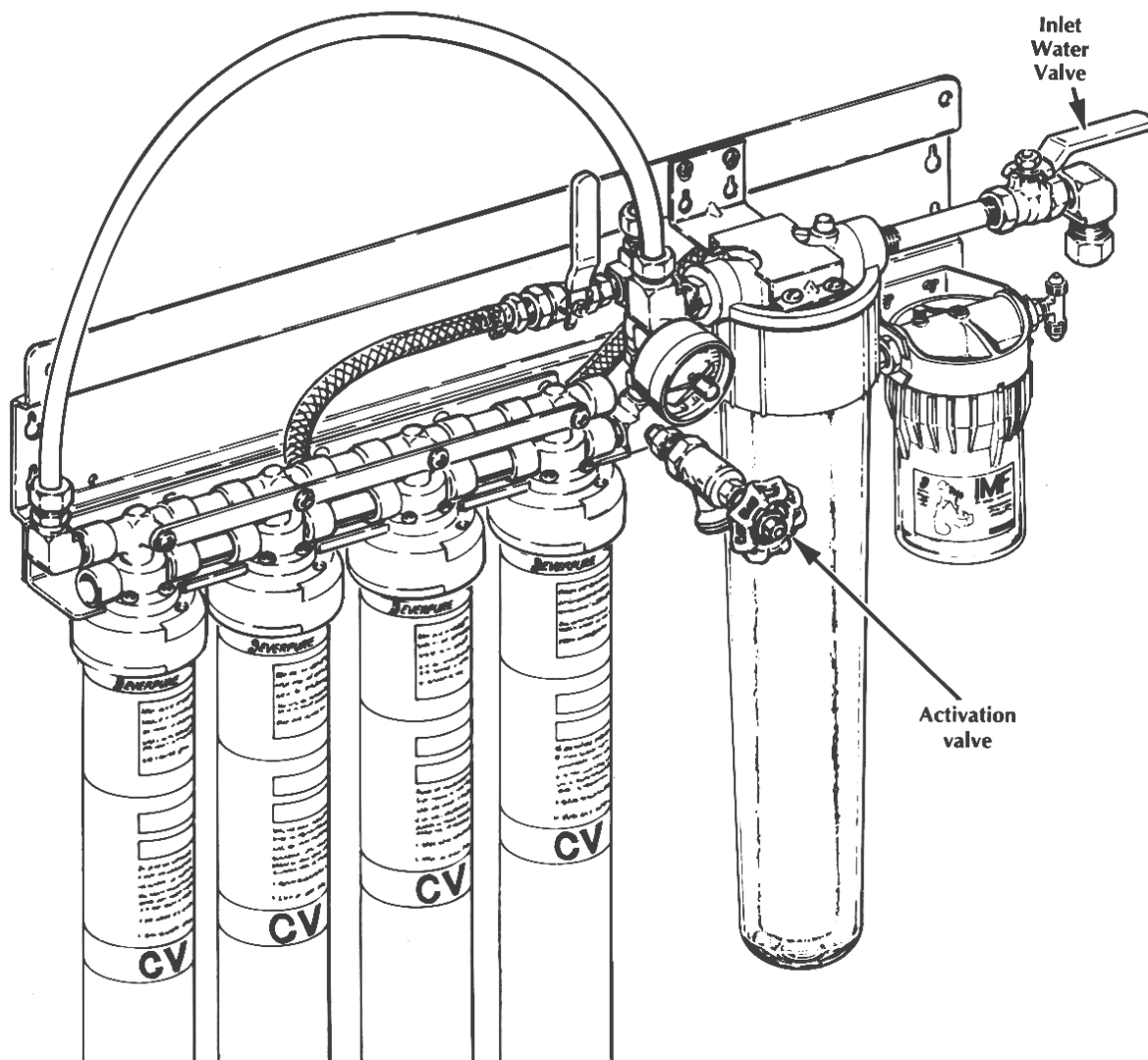

Figure 1—QUAD SYSTEM

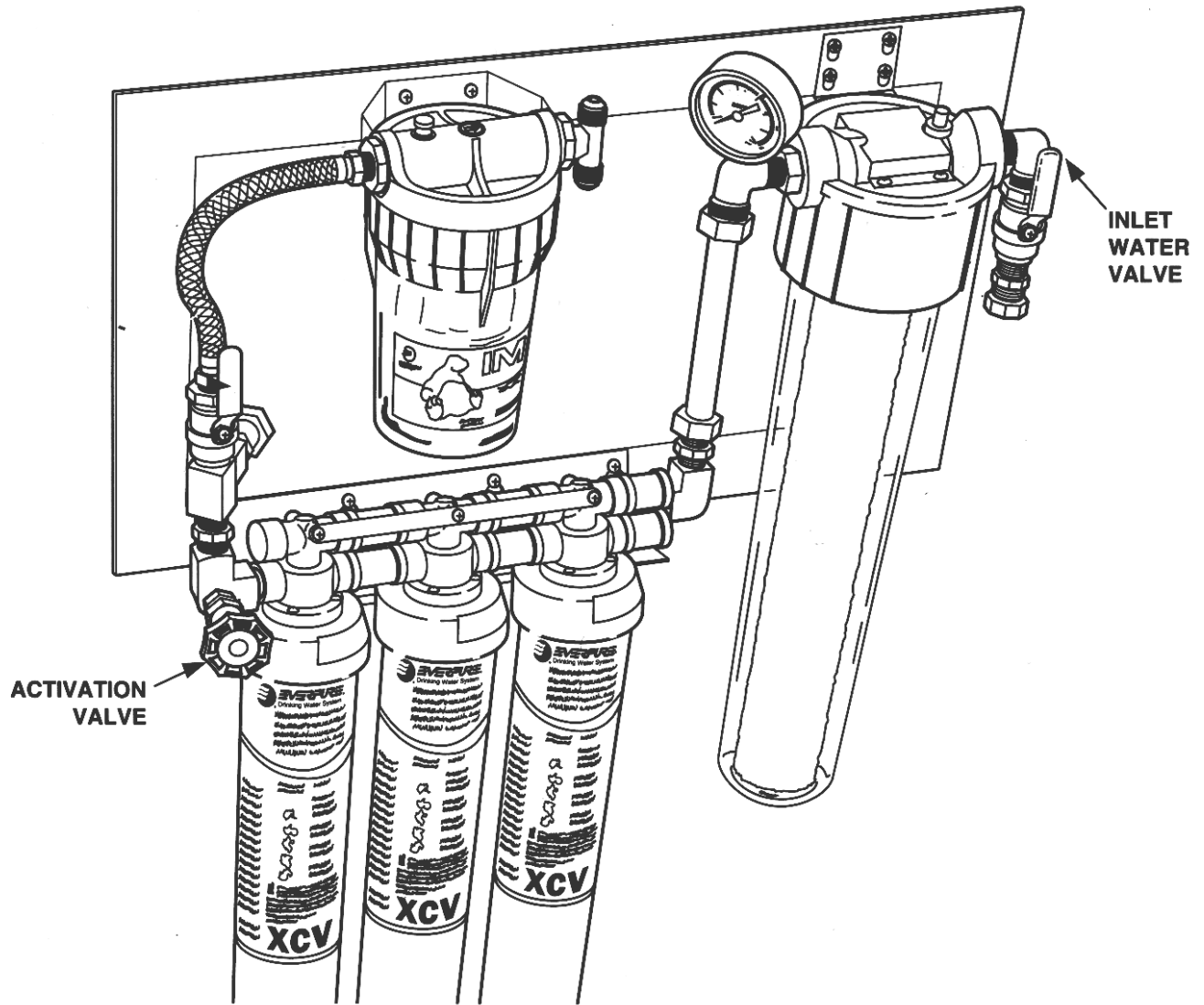

Figure 1—TRI-PACK SYSTEM

REMOVAL

3. Rotate the cartridge to the left until it stops. (Some trapped water may drop as the cartridge is loosened.) (Figure 2)
4. Pull the cartridge downward and out of the head.

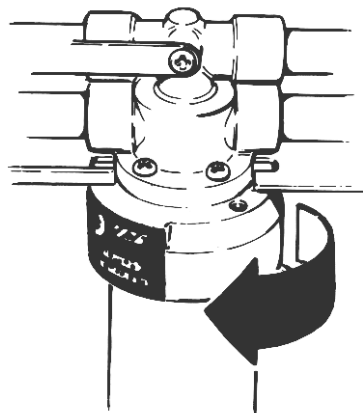

Figure 2

REINSTALL

- 5. Orient 1 of the raised blisters on the rim of the new cartridge with the black and white head label. Remove protective wrapping and insert the cartridge straight up into the ring. (Make sure CV cartridges are installed on the Quad System and XCV cartridges are installed on the Tri-Pack System. (Figure 3A)

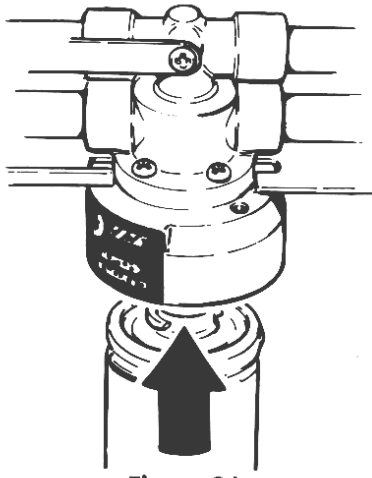

Figure 3A

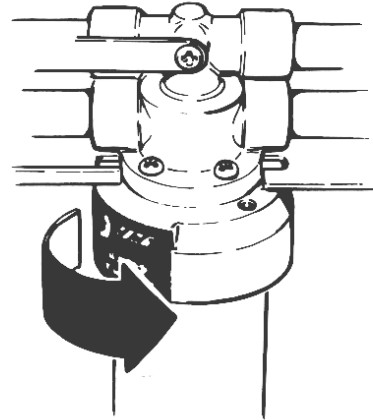

Figure 3B

- 6. Rotate the cartridge to the right until it stops. (Figure 3B)
- 7. Repeat Steps 3 through 6 for the remaining cartridges.
- 8. Record current date in space provided on cartridge label.
- 9. Insure activation valve is still open.
- 10. Activate the cartridges by slowly opening inlet water valve completely and let water run to drain for 5 minutes at maximum flow.

Caution

Activating for less than the prescribed time will significantly reduce cartridge life.

- 11. Close activation valve and remove garden hose. (Figure 1)
- 12. Check for leaks. If there are leaks see troubleshooting section of the *Equipment Manual*.
- 13. If there are no leaks cartridge changeout is complete.
- 14. Turn power back ON to all equipment.