

When
Semi-annually

Tools
None required.

Beverage Systems

Everpure, Inc.: Quad and Tri-Pack Systems

Precaution

Essential that this procedure be performed during non-business hours.

Cartridge Changeout

1. Shut OFF water to system. Turn OFF power to coffee, ice and post mix.
2. Connect garden hose to flushing valve, run to drain and secure. Open flushing valve on head by turning COUNTERCLOCKWISE to relieve water pressure. (Flushing valve should remain open). (Figure 1 for Quad or Tri-Pack system)

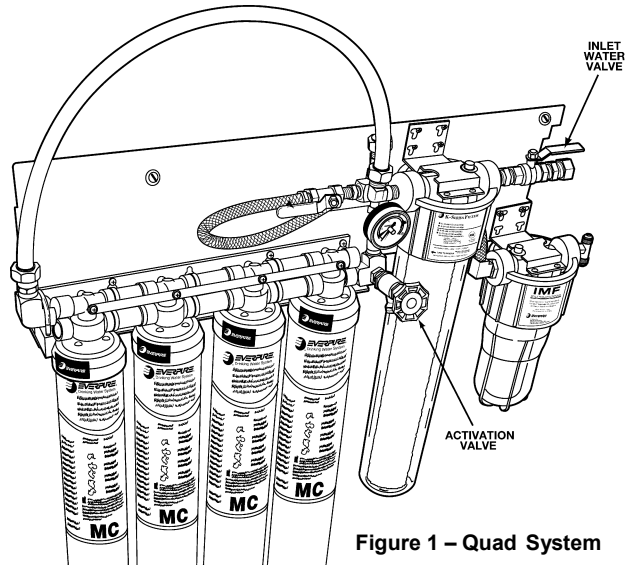

Figure 1 – Quad System

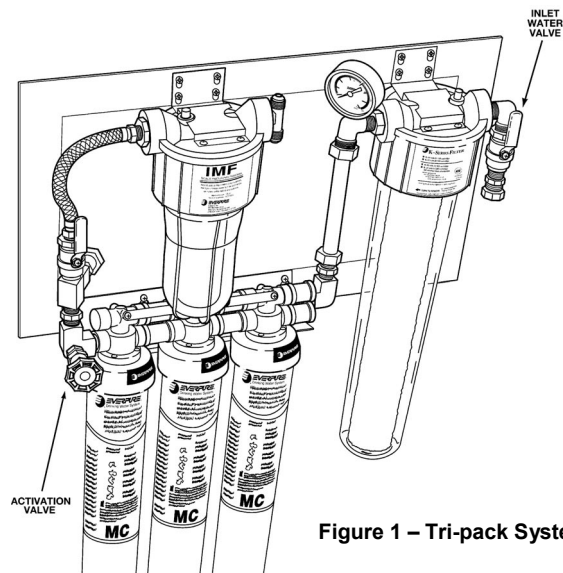
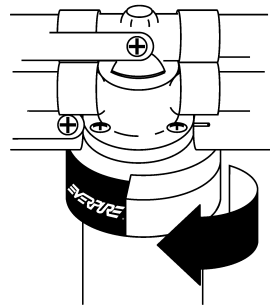

Figure 1 – Tri-pack System

REMOVAL

3. Rotate the cartridge to the left until it stops. (Some trapped water may drop as the cartridge is loosened.) (Figure 2)
4. Pull the cartridge downward and out of the head.



REINSTALL

5. Orient one of the raised blisters on the rim of the new cartridge with the black and white head label. Remove protective wrapping and insert the cartridge straight up into the ring. (Figure 3A)

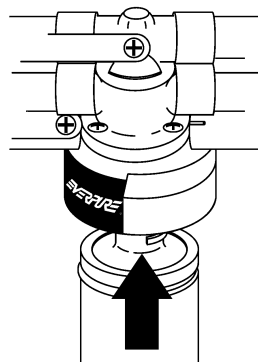

Figure 3A

Figure 2

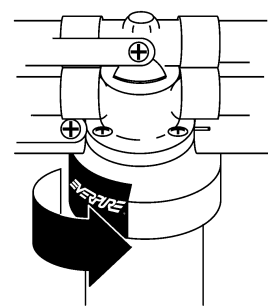

Figure 3B

6. Rotate the cartridge to the right until it stops. (Figure 3B)
7. Repeat Steps 3 through 6 for the remaining cartridges.
8. Record current date in space provided on cartridge label.
9. Insure flushing valve is still open.
10. Flush the cartridges by slowly opening inlet water valve completely and let water run to drain for 5 minutes at maximum flow.

CAUTION: Flushing for less than the prescribed time will significantly reduce cartridge life.

11. Close flushing valve and remove garden hose. (Figure 1)
12. Check for leaks. If there are leaks see troubleshooting section of the Equipment Manual.
13. If there are no leaks cartridge changeout is complete.
14. Turn power back ON to all equipment.