



BRS

Back Room System

IMI Cornelius is proud to introduce a new modular and pre-configured Back Room System designed for the environmentally friendly soda circuit product range Energize.

Key features

- All stainless steel back room stand to hold Energize4 or Energize5 unit
- 2 Shelves to hold 8 x 20 litre Bag-in-Boxes
- Side mounting panels for installing gas board and Quad Pack, MC3 or MH water filtration systems
- Integrated gas and water distribution panel with European regulators
- Integral pump panel with 8 syrup pumps, 1,2 or 3 bag selectors



All information contained in this document is the property of IMI Cornelius and should not be passed to any third party without prior written consent.

© IMI Cornelius

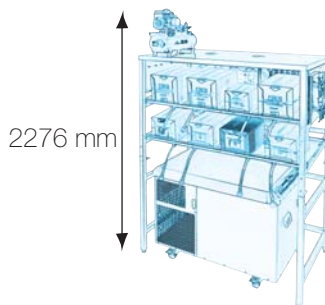
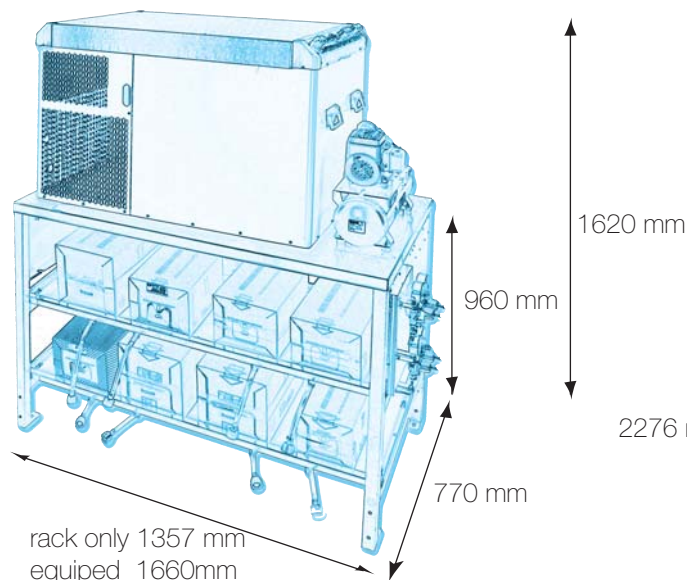

Technical data

Syrup Pumps: Shurflo or Flojet

Dimensions rack only

Height: 960 mm
 Width: 1357 mm
 Depth: 770 mm

Dimensions including filter pack and gas panels

Height: 960 mm
 Width: 1660 mm
 Depth: 770 mm

Dimensions including , Energize4 on top, filter pack, gas panels and compressor

Height: 1620 mm
 Width: 1660 mm
 Depth: 770 mm

Dimensions including leg extension, Energize5 below, filter pack, gas panels and compressor

Height: 2276 mm
 Width: 1660 mm
 Depth: 770 mm

Weight

Rack: 80 kg
 Leg extension: 20 kg
 Filter pack: 10 kg
 Gas panel: 10 kg
 Compressor: 17 kg

Variations and order numbers Back Room System

8 Flojet pumps 1 BIB changer 22 0110 559
 8 Shurflo pumps 2 BIB changer 22 0110 904
 8 Shurflo pumps 3 BIB changer 22 0110 903

Options

Leg extension kit 22 0111 037
 Air compressor 14 9590 834
 Water booster system 07 0000 721
 Surge tank 07 0000 722
 Wall shelf for air-compressor or booster 22 0076 100
 Wall shelf for booster and surge tank 61 1000 360
 Water filtration system Country specific

IMI Cornelius reserves the right to modify the details in the publication as products and specifications are updated and improved. All data contained in this literature is correct at time of print. To ensure technical data is accurate please contact IMI Cornelius prior to placing your order.



United Kingdom

T: +44 (0) 870 905 0773
 F: +44 (0) 1142 320 067
 E: customerservice@corneliusuk.com
 www.corneliusuk.com

Germany

T: +49 (0) 2173 793 0
 F: +49 (0) 2173 774 38
 E: info@imi-cornelius.de
 www.imi-cornelius.com

